



Waste Heat Recovery System (WHRS)

for Reduction of Fuel Consumption,
Emissions and EEDI

Engineering the Future – since 1758.

MAN Diesel & Turbo



Contents

Summary	5
Introduction	5
Description of the Waste Heat Recovery Systems	6
Power concept and arrangement	6
Power turbine and generator (PTG)	7
Steam turbine and generator (STG)	7
Steam turbine, power turbine, and generator (ST-PT).....	8
Main engine and WHRS system control.....	10
Installation aspects	11
Power turbine WHRS solution	12
Steam turbine WHRS solution	12
Full steam and power turbine WHRS solution	12
Main Engine Performance Data	15
Main engine tuning for WHRS	15
Exhaust gas bypass with power turbine.....	15
Exhaust gas bypass without power turbine.....	15
Exhaust gas boiler and steam systems.....	16
Single-pressure steam system	16
Dual-pressure steam system	17
Steam and water diagram – ME WHRS element	18
Main engine steam production power (SPP) guarantee	19
Obtainable Electric Power of the WHRS.....	20
Power and steam turbine generator output – dual pressure	20
Payback time for waste heat recovery system	22
Emission Effects of using WHRS.....	25
WHRS Effect on Ship's EEDI.....	26
Conclusion.....	28
Reference	28
Nomenclature / abbreviations	29

Waste Heat Recovery System (WHRS)

for Reduction of Fuel Consumption, Emission and EEDI

Summary

The increasing interest in emission reduction, ship operating costs reduction and the newly adapted IMO EEDI rules calls for measures that ensure optimal utilisation of the fuel used for main engines on board ships.

Main engine exhaust gas energy is by far the most attractive among the waste heat sources of a ship because of the heat flow and temperature. It is possible to generate an electrical output of up to 11% of the main engine power by utilising this exhaust gas energy in a waste heat recovery system comprising both steam and power turbines, and combined with utilising scavenge air energy for exhaust boiler feed-water heating.

This paper describes the technology behind waste heat recovery and the potential for ship-owners to lower fuel costs, cut emissions, and the effect on the EEDI of the ship.

Introduction

Following the trend of a required higher overall ship efficiency since the first oil crisis in 1973, the efficiency of main engines has increased, and today the fuel energy efficiency is about 50%. This high efficiency has, among other things, led to low SFOC values, but also a correspondingly lower exhaust gas temperature after the turbochargers.

Even though a main engine fuel energy efficiency of 50% is relatively high, the primary objective for the ship-owner is still to lower ship operational costs further, as the total fuel consumption of the ship is still the main target. This may lead to a further reduction of CO₂ emis-

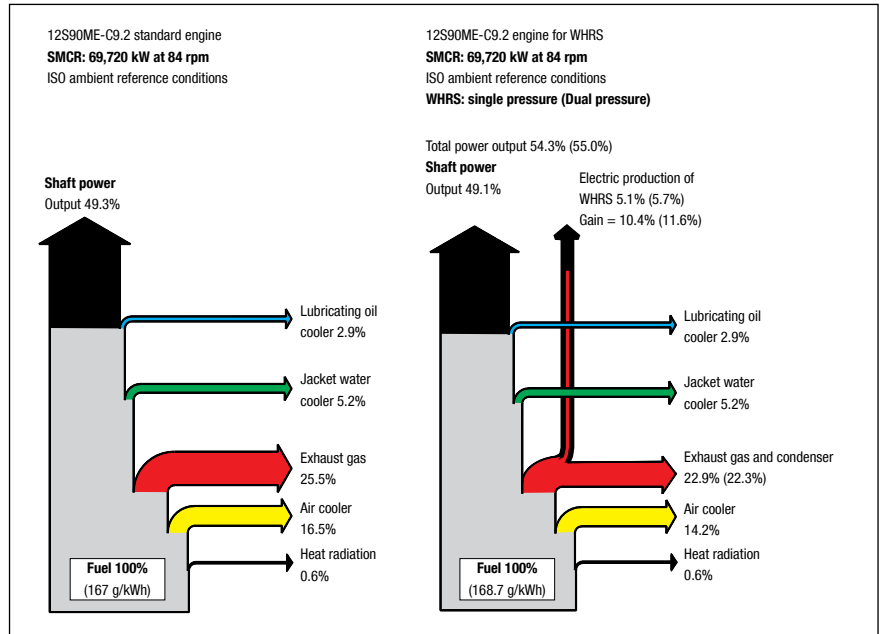

Fig. 1: Heat balance for large-bore MAN B&W engine types without and with WHRS

sions – a task, which is getting even more important with the new IMO EEDI rules in place from 2013.

The primary source of waste heat of a main engine is the exhaust gas heat dissipation, which accounts for about half of the total waste heat, i.e. about 25% of the total fuel energy. In the standard high-efficiency engine version, the exhaust gas temperature is relatively low after the turbocharger, and just high enough for producing the necessary steam for the heating purposes of the ship by means of a standard exhaust gas fired boiler of the smoke tube design.

However, the MAN B&W two-stroke ME main engine tuned for WHRS will increase the possibilities of producing electricity from the exhaust gas. The result will be an improvement in total efficiency but a slight reduction of the efficiency of the main engine will be seen.

Fig.1 shows a comparison of engine heat balances, with and without WHRS. The figure shows that for the engine in combination with WHRS the total efficiency will increase to about 55%.

The IMO EEDI formula allows for considering adding WHRS into the ship, analyse EEDI effects and EEDI settings. As an even lower CO₂ emission level can be achieved by installing a waste heat recovery system the EEDI, which is a measure for CO₂ emissions, will also be lowered.

Today several different WHRSs are readily available. Depending on the level of complexity acceptable to the owner and shipyard and the actual electrical power consumption on-board, it is possible to choose between the following systems:

- ST-PT – Steam Turbine-Power Turbine generator unit (Power turbine, steam turbine, gear and generator unit with single or dual pressure steam turbine)
- STG – Steam Turbine Generator unit (Steam turbine, gear and generator unit, single or Dual steam pressure)
- PTG – Power Turbine Generator unit (Power turbine, gear and generator unit).

In the future, special variants and combinations of the above systems may be foreseen, particularly with the fulfilment of Tier III concerning NO_x from 2016 and other future regulations.

Description of the Waste Heat Recovery Systems

Power concept and arrangement

The principle of the WHRS-tuned MAN B&W low speed diesel engine is that part of the exhaust gas flow is bypassed the main engine turbocharger(s) through an exhaust gas bypass.

As a result, the total amount of intake air and exhaust gas is reduced. The reduction of the intake air amount and the exhaust gas amount results in an increased exhaust gas temperature after the main engine turbocharger(s) and exhaust gas bypass. This means an increase in the maximum obtain-

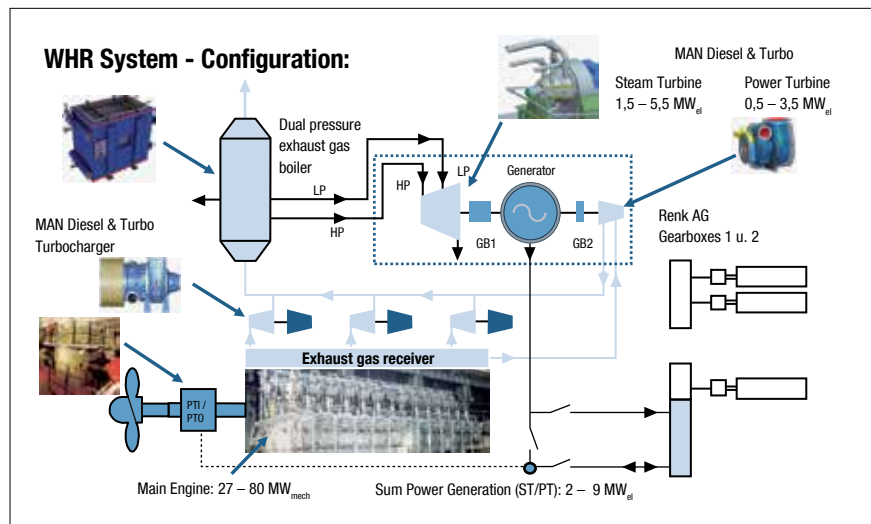

Fig. 2: Waste heat recovery system principles

able steam production power for the exhaust gas fired boiler – steam, which can be used in a steam turbine for electricity production.

Also, the revised pressure drop in the exhaust gas bypass, which is part of the WHRS, can be utilised to produce electricity by applying a power turbine. The main WHRS principles are shown in Fig. 2.

As mentioned before, a WHRS consist of different components, and may vary as a stand-alone installation or a combined installation

Choosing a system for a project depends on the power demand onboard the ship (electrical load at sea), the ship's running profile (hours at different main engine loads at sea), the acceptable payback time for the proposed WHRS solution based on the running profile and the space available on the ship, among others.

A very important part of selecting the best WHRS for a ship project is choos-

ing the best suited propulsion power and rpm for the ship – biggest possible propeller – so as to ensure the lowest possible fuel consumption for the basic performance of the ship. For more information on this topic, we refer to the MAN Diesel & Turbo paper "Basic Principles of Ship Propulsion", see Ref. 1.

In many cases, WHRS will be able to supply the total electricity need of the ship as a standalone power source, but it can also run in parallel with a shaft generator, shaft motor and auxiliary diesel generating sets. This type of advanced power system requires an advanced power management system (PMS), with which the MAN Diesel & Turbo engine control system is designed to communicate.

Particularly for container ship designs, WHRS has found its place where it contemplates a technological step forward in lowering fuel consumption and CO_2 emissions of the ship, but the interest for WHRS solutions is spreading to other ship types with the aim of re-

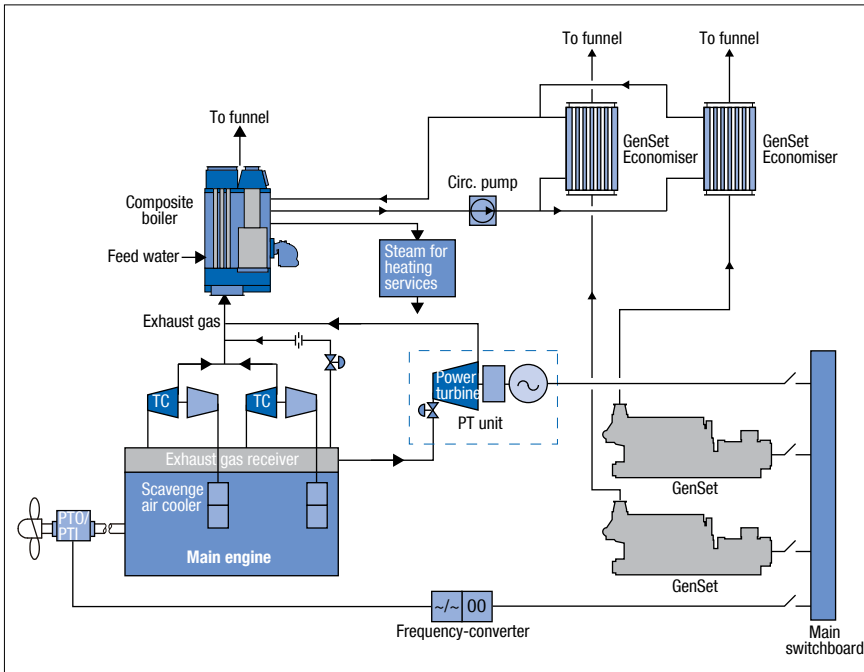

Fig. 4: Schematic diagram of the WHRS-PTG system

ducing total fuel costs, ship EEDI and emissions.

Power turbine and generator (PTG)

The simplest and cheapest system consists of an exhaust gas turbine (also called a power turbine) installed in the exhaust gas bypass, and a generator that converts power from the power turbine to electricity on-board the ship, see Fig. 4.

For power turbine solutions, the main engine receiver will be equipped with two exhaust gas connections, one for engine exhaust gas by-pass (EGB) and one for the power turbine. The connection for the power turbine must typically be larger as the power turbine unit typically is arranged several meters away from the main engine in the engine room. The exhaust gas by-pass with exhaust gas bypass control valve and orifice is part of the engine delivery and will be tested at the engines shop test.

The power turbine and the generator are placed on a common bedplate. The MAN Diesel & Turbo TCS-PTG power range is shown in Fig. 5.

TCS-PTG stands for Turbo Compound System – Power Turbine Generator and is an MAN Diesel & Turbo product.

The power turbine is driven by part of the exhaust gas flow which bypasses the turbochargers. The power turbine produces extra output power for electric power production, which depends on the bypassed exhaust gas flow amount.

The PTG WHRS solution can both be a standalone and / or parallel running electric power sourcing for the ship.

The exhaust gas bypass valve will be closed at an engine power lower than about 40% SMCR, down to an engine load point where power utilization for the power turbine is economical desirable, which stop when the ancillary engine blower(s) start.

Using a TCS-PTG WHRS solution will provide a 3-5% recovery ratio, depending on the main engine size.

For more information on TCS-PTG, see Ref. 2.

Steam turbine and generator (STG)

The second system builds on the principle exhaust gas bypass and, thereby,

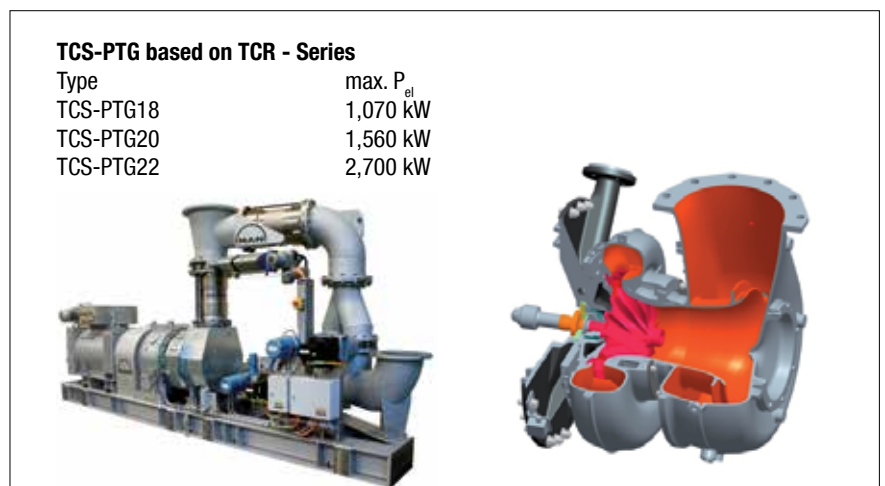

Fig. 5: MAN Diesel & Turbo TCS-PTG WHRS power range

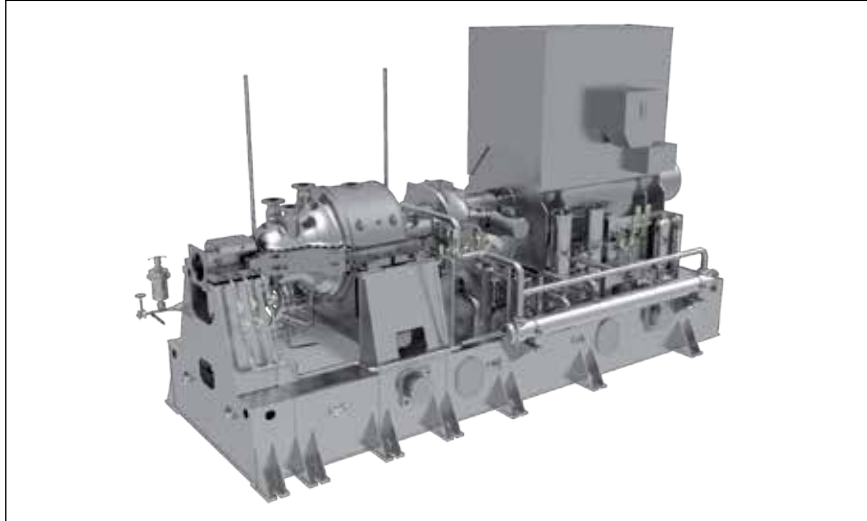

Fig. 6: WHRS steam turbine generator unit

increasing the exhaust gas temperature before the boiler without using a power turbine.

When applying the steam turbine (ST) as a stand-alone solution, the exhaust gas bypass stream is mixed with the exhaust outlet from the turbocharger(s), increasing the exhaust gas temperature before the boiler inlet.

When part of the exhaust gas flow is bypassed the turbocharger, the total amount of air and gas will be reduced, and the exhaust gas temperature after the turbocharger and bypass will increase. This will increase the obtainable steam production power for the exhaust gas fired boiler.

By installing a steam turbine (often called a turbo generator), the obtainable steam production from the exhaust boiler system can be used for electric power production. The steam turbine is installed on a common bedplate with the generator in the same manner as the power turbine and the generator. Fig. 6 shows the STG solution.

Like the PTG design, the STG solution can function both as a stand-alone and as a parallel running electric power source for the ship – depending on the actual demand for the particular ship design.

Using a WHRS STG system, it will be possible to recover some 5 to 8%, depending on the main engine size, engine rating, and ambient conditions.

Steam turbine, power turbine, and generator (ST-PT)

If the electric power demand on the ship is very high, e.g. a container ship, the power turbine and the steam turbine can be built together to form a combined system. The power turbine and the steam turbine is built onto a common bedplate and, via reduction gearboxes, connected to a common generator, see Fig. 7.

The power output from the power turbine can be added to the generator via a reduction gear with a special clutch. However, first the steam turbine will start at 30 – 35% SMCR main engine power followed by the power turbine which starts power production at 40 to 50% SMCR.

The combined WHRS ST & PT schematic diagram can be seen in Fig. 8, which shows a system that, in many conditions, reduces the fuel costs of the ship considerably by being able to cover the total electric power needs in many conditions onboard the ship. Otherwise, a shaft motor / generator

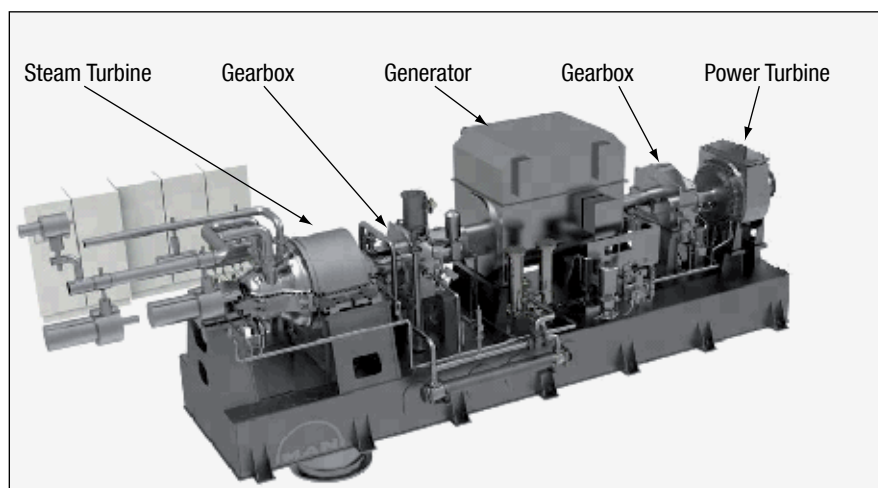

Fig. 7: Full WHRS steam and power turbine unit

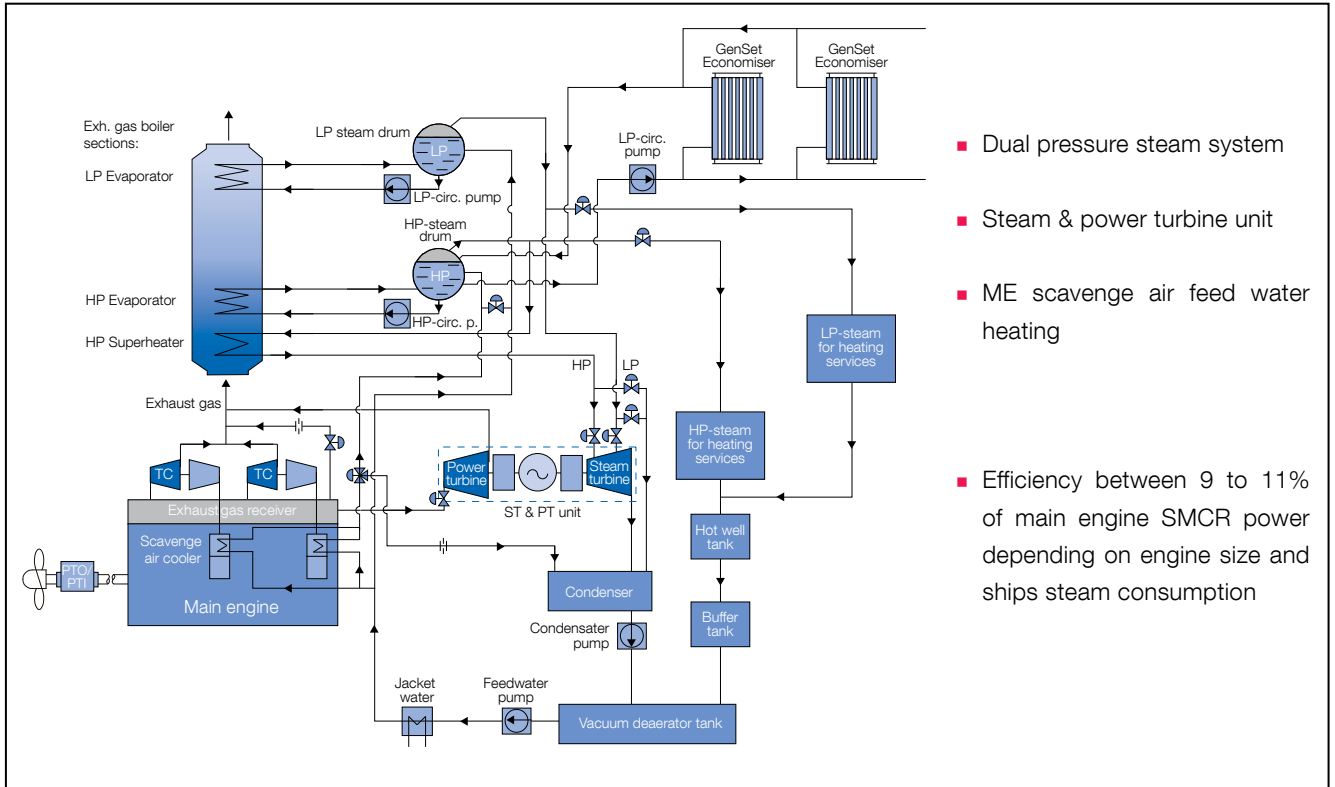

Fig. 8: Schematically diagram of the WHRS ST-PT system

(PTI/PTO) connected to the main engine shaft could be an option, see Fig. 8, making it possible to add either electric power to the ship grid if needed, or to boost propulsion by supplying the electric power to the PTI.

Selecting the full WHRS – combining both steam and power turbines – some 8-11% power can be recovered, depending on the main engine size, engine rating and ambient conditions.

Choosing the system most suitable for a specific ship project requires careful evaluation based on requirements concerning fuel efficiency, arrangement restrictions, emission requirements, operational profile for the ship, payback time, etc.

The project conditions vary from case to case as the opinion on acceptable payback time differs among shipowners. Still, the below guidelines may be very useful when evaluating a new ship project and the potential for utilising WHRS advantages.

As a rule of thumb, we recommend the following:

Main engine power > 25,000 kW → Combined ST and PT

Main engine power < 25,000 kW → PTG or STG (e.g. with super heater)

Main engine power < 15,000 kW → PTG or ORC (Organic Rankine Cycle) *

*ORC will not be covered further in this paper.

Main engine and WHRS system control

The main engine control and the WHRS control must be able to function as an integrated part of the total control system of the ship, which means that integration between the systems shown in Fig. 9 must be in place.

The development of the WHRS and main engine controls is based on the ship owner's demand for full control and optimum fuel consumption in all operational modes. Focus is very much on fuel economy because of the continuously increasing fuel oil prices.

A central part of this is the ship's power management system, which controls the different power sources on-board, so that minimum fuel consumption can be pursued for the different sailing conditions.

It is therefore very important to understand the complexity of the power systems (propulsion and electric power sources) and their interfacing when planning the control functions and interfaces for the main engine and WHRS control.

The engine control and the WHRS control have to be strongly integrated because the WHRS steam turbine and power turbine use the energy in the exhaust gas to recover energy. The dynamics of the main engine will influence the behaviour of the steam turbine and power turbine.

The connection between the main engine and WHRS can be seen in Fig. 10, showing the exhaust gas flow between engine, power turbine and exhaust

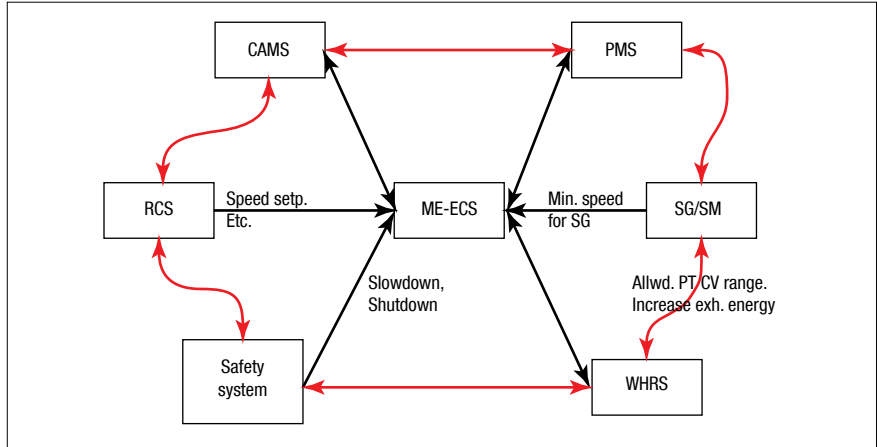

Fig. 9: Ship control systems normally found onboard a large vessel.

boiler. Two exhaust connection on engine exhaust receiver is necessary for WHRS arrangements including power turbine.

The basis for this layout of the connections between the engine and WHRS components is two-sided as the control must first be able to protect the engine against unacceptable conditions, and second ensure maximum available power for the WHRS. This is done by controlling the exhaust gas bypass

amount, keeping it within acceptable limits.

This is ensured by controlling the exhaust gas bypass (EGB) control valve via the engine control system and the power turbine control valve. The sum of exhaust bypasses must always be within the allowed bypass amount selected for the particular engine with WHRS tuning. Fig. 11 shows the control principle of these valves.

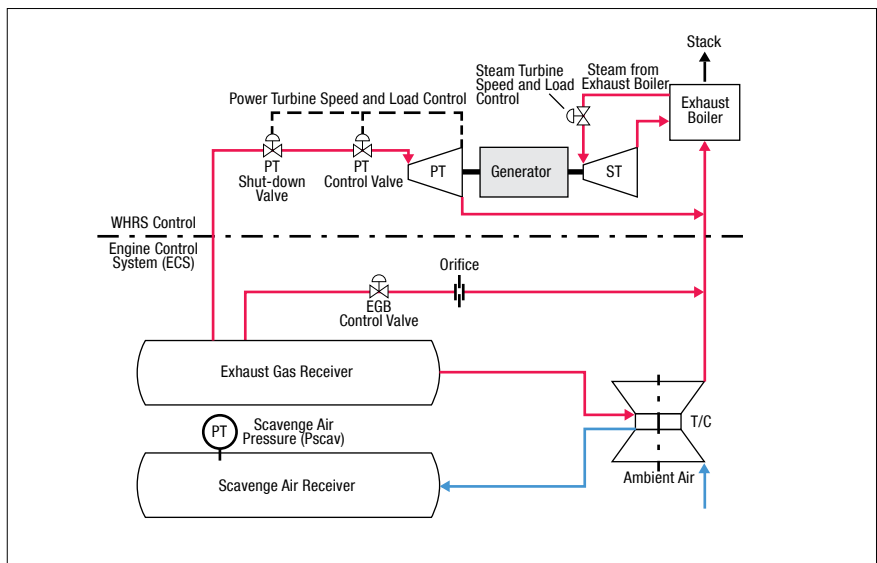

Fig. 10: Control strategy of the WHRS ST-PT system

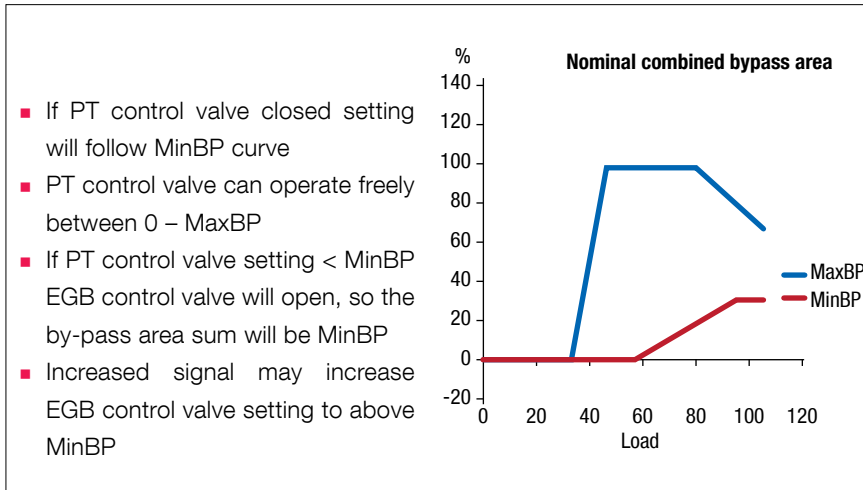

Fig. 11: Control strategy of the WHRS ST-PT system – bypass control

The blue curve in Fig. 11 slopes downwards after 100% main engine load. This is to balance the thermal protection of the main engine while at the same time maximizing the energy for the power turbine, both within the maximum allowed turbine pressure (pscav).

The WHRS control system must give the position of the power turbine control valve, so that the engine control system can compensate by controlling the EGB valve position.

The power turbine control valve controls the exhaust gas amount to the power turbine and, thereby, controls the power turbine output to the generator.

In the same way, the steam turbine governor system controls the steam amount being fed into the steam turbine and, thereby, also the output to the generator. In addition, the steam turbine governor system also controls the generator output frequency because of the slow reaction to steam changes.

When producing too much electric power, the (high pressure) superheated steam to the steam turbine is controlled by a speed control governor through a single throttle valve, which means that the surplus steam is dumped via a dumping condenser. When the generator is operating in parallel with the auxiliary diesel generators, the governor operates in the normal way to give correct load sharing.

The power management system (PMS) of the ship is configured so that it prioritises the power sources in the following way:

1. WHRS generator
2. PTO generator (if installed)
3. Auxiliary diesel generators
4. PTI motor (if installed)

So if power from the WHRS generator is available, it will be utilised first. If more power is needed, then the PTO generator should be utilised and, after this, the diesel generators. This will support a low fuel consumption for the ship. The PTI motor will be used to boost propulsion if the WHRS generator generates more power than needed by the ship.

Installation aspects

The decisive aspects when choosing a WHRS installation for a new ship project are the size of the system and the complexity of the piping and cabling, and other preparations to be considered by the shipyard.

All WHRS generator systems are prepared on a common bedplate, where the different components already are installed and assembled. The main concerns of the shipyard are therefore to find space in the machinery room on-board – near the main engine installation – for foundation, piping and cabling between these main components.

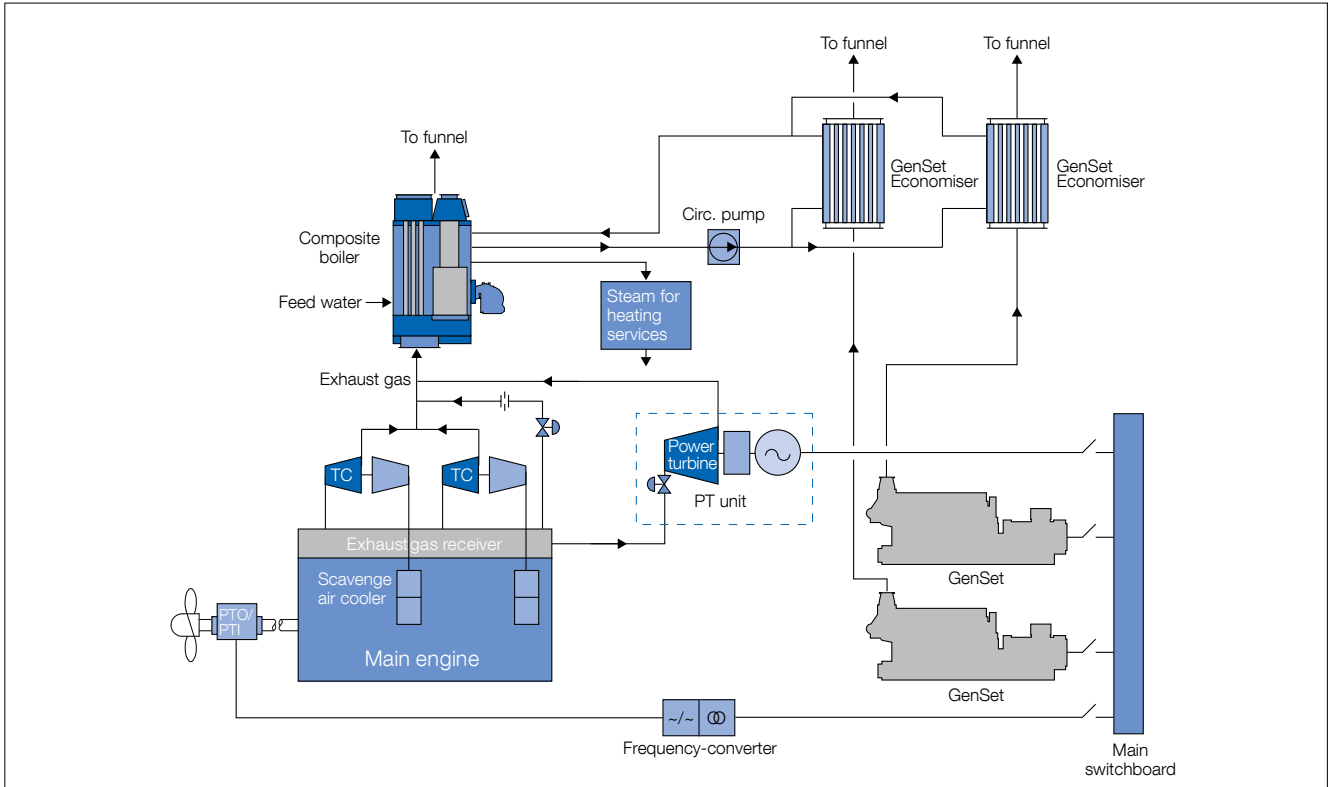

Fig. 12: Power turbine diagram

Power turbine WHRS solution

The simplest installation is considered to be the WHRS PTG system, as the system is the smallest of the different systems, and because the main connection between the WHRS PTG and the MAN B&W engine is only the exhaust gas by-pass line. Fig. 12 shows an example of a diagram.

Steam turbine WHRS solution

The steam turbine installation is quite extensive as many different components must be connected. Firstly, it is likely that the boiler installation has to be increased in size. From the boiler, one or two pipes should be connected to the steam turbine, depending on whether the single or dual pressure system is applied. The condenser must be installed under the bedplate of the steam turbine and, in some cases, it

may be as large as the steam turbine and generator installation. The condenser piping is connected to the boiler system so that the water can be recir-

culated. The condenser is furthermore equipped with cooling water piping. Fig. 13 shows the typical steam turbine stand-alone solution.

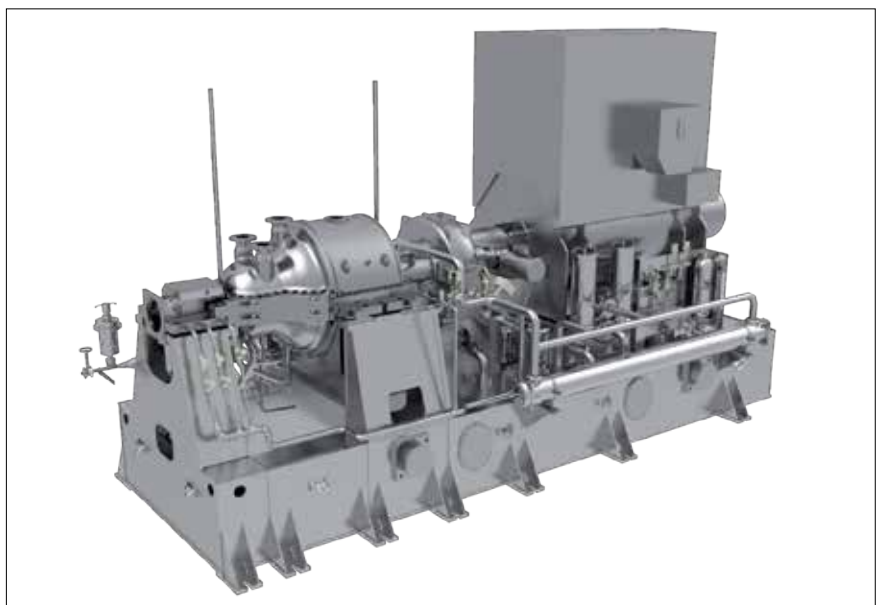

Fig. 13: Steam turbine generator unit

As mentioned above the WHRS steam turbine solution will require space for a large condenser installation, as shown in fig. 14, an aspect which the shipyard needs to consider in respect of the machinery room.

Full steam and power turbine WHRS solution

If the combined PT-TG system is considered, a number of installation aspects must be considered. The power turbine will need an inlet and exhaust gas pipe connected to the existing exhaust gas system. The steam turbine requires the piping system mentioned in the previous paragraph.

One challenging installation aspect is the fact that the power turbine takes the exhaust gas from the exhaust gas receiver, which sits on the engine, and the steam turbine receives steam from the boiler system, which can be situated some distance away from the engine. Fig. 15 shows the relation of the turbines, generator and condenser installations.

With WHRS including steam turbine, more space is required in the engine room and casing areas. Steam exhaust boilers, normally as a dual pressure system, will include the following main components:

- LP economiser
- LP steam drum
- HP economiser
- HP super heater
- HP steam drum
- Pumps, etc.

Details of these components (dimensions, electrical demand, etc.) can be supplied by the WHRS package supplier or the exhaust boiler supplier.

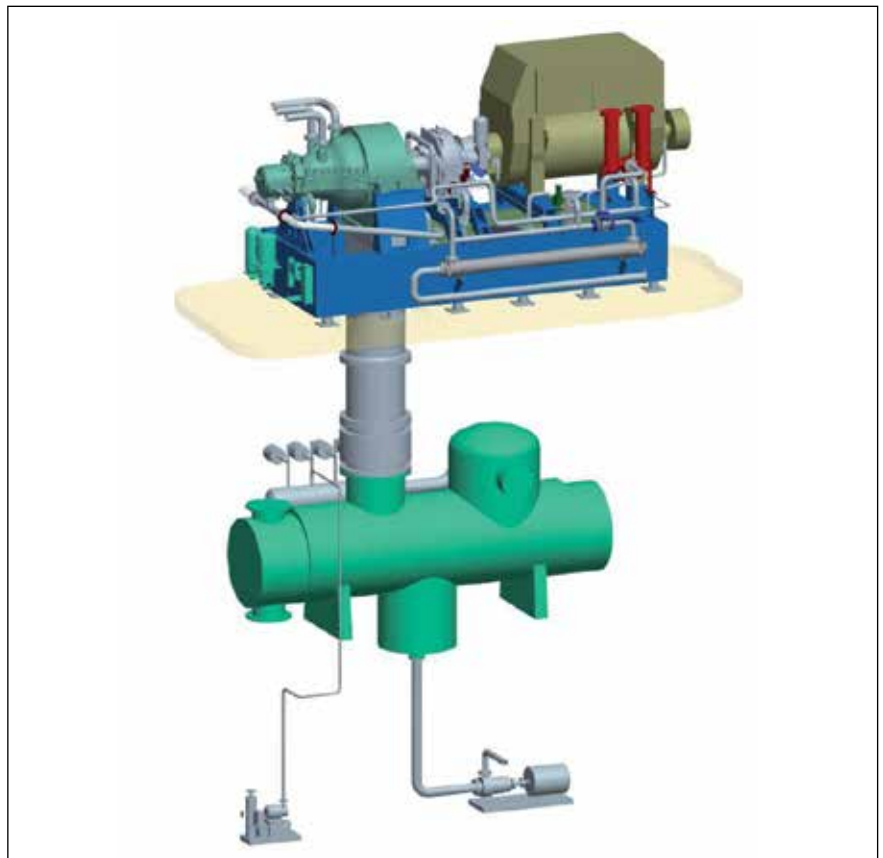

Fig. 14: Steam turbine generator unit

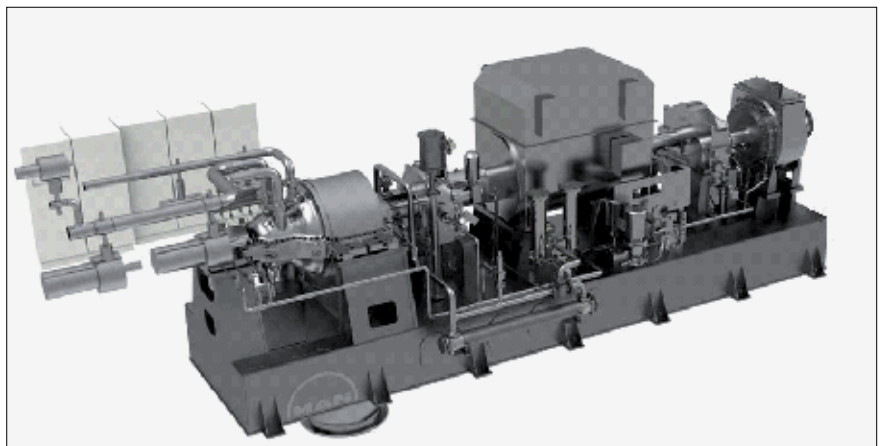

Fig. 15: Steam turbine and power unit

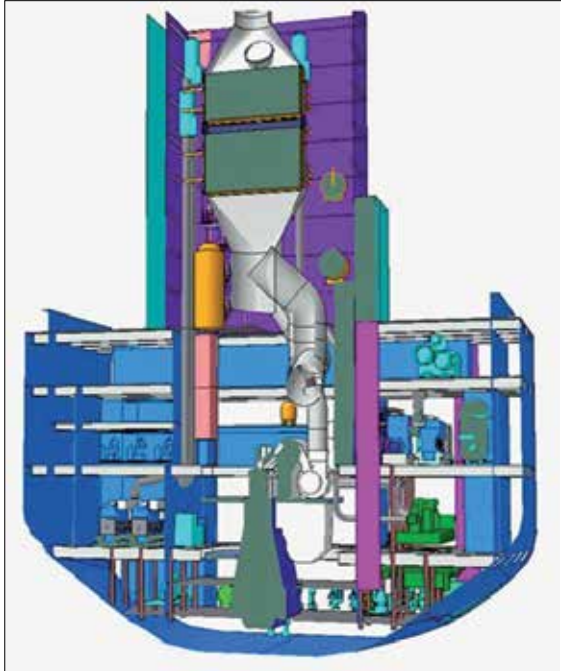

Fig. 16: Container ship engine room and casing arrangement - transversal section

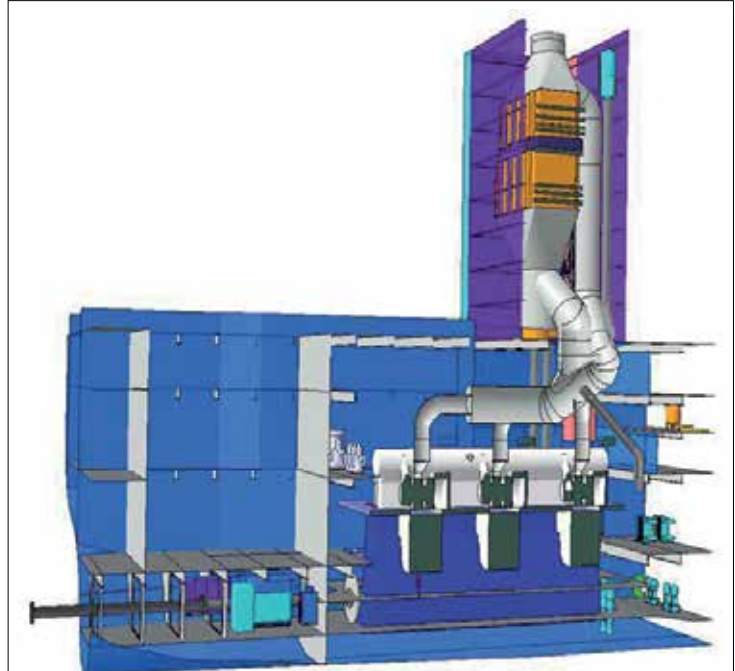

Fig. 17: Container ship engine room and casing arrangement – horizontal section

The ship designers must make reserve space for all components in the machinery arrangements and casings – a typical arrangement for a container ship can be seen in Figs. 16 and 17.

The exhaust boiler (LP & HP) can be as big as the main engine, see Fig. 16, a point that often surprises shipyards which have not built ships with WHRS included before.

Fig. 17 shows that exhaust boilers, water tube type, require the installation of an exhaust bypass. This bypass is recommended to be open whenever the main engine load is below 30% and the exhaust valve before the exhaust boiler closed. Low engine load also means low exhaust velocity through the exhaust boiler, which increases the risk of soot deposits and soot fire, Ref. [3].

The exhaust flow into the exhaust boiler is very important to ensure the best ex-

haust boiler steam output and WHRS generator output. An even exhaust gas velocity distribution below the exhaust boiler is required to secure the boiler manufacturers' stipulated steam output figures, see Fig. 18. Computational fluid dynamics (CFD) calculation methods can be used to place guide vanes cor-

rectly in the exhaust flow in the piping system.

The back pressure of the whole exhaust system must also be carefully checked to ensure that main engine performance are not affected negatively, see Fig. 19.

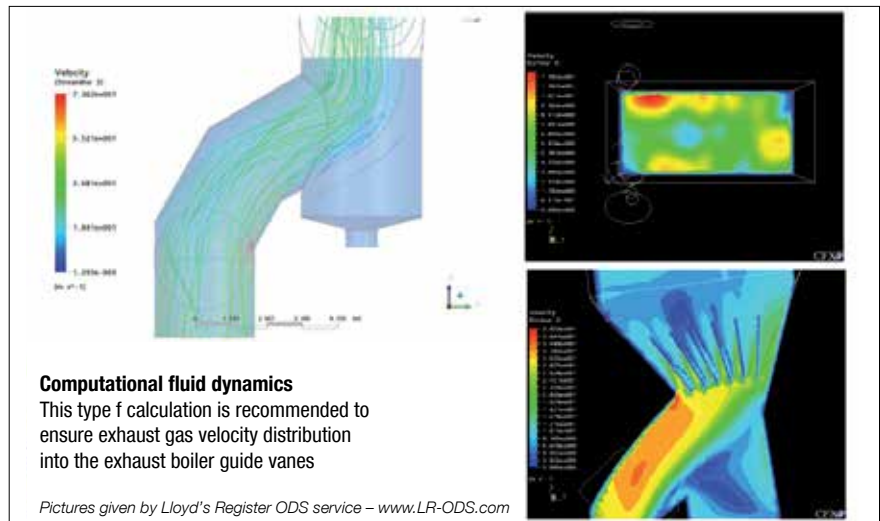

Fig. 18: CFD calculations for placing guide vanes in the exhaust flow.

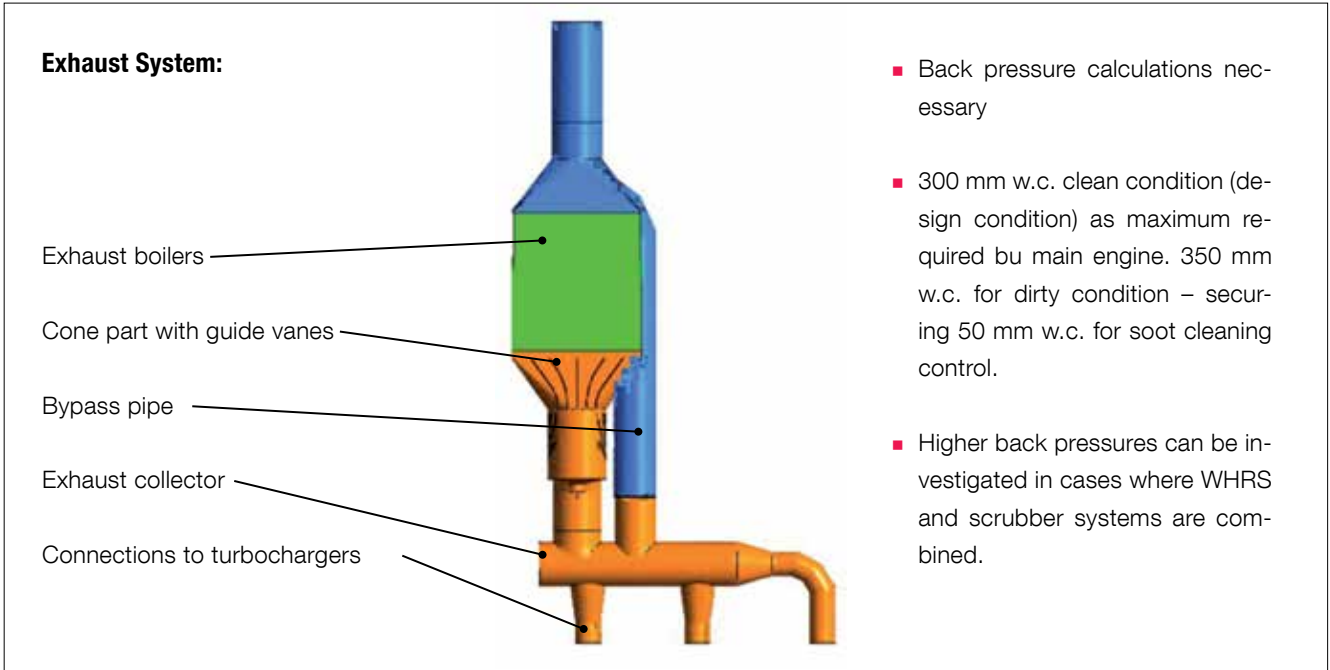

Fig. 19: Exhaust system with WHRS exhaust boilers.

If scrubbers are added to fulfil IMO or local ECA sulphur regulations, engine data can be calculated for higher back pressures, if required.

Main Engine Performance Data

Main engine tuning for WHRS

MAN Diesel & Turbo offers main engines tuned for WHRS, which results in an increase in total system efficiency as described in the introduction – details about the WHRS tuning of our engines are given in the following.

Exhaust gas bypass with power turbine

The exhaust gas bypass and turbine are available with the following approx. effects, compared with a standard high-efficiency main engine version without an exhaust gas bypass, Table I.

Exhaust gas bypass without power turbine

If only the steam turbine solution is chosen as application, the exhaust gas bypass is installed with an orifice. The

engine parameters for this engine application are shown in Table II.

Because the exhaust gas bypass is not fitted with an exhaust gas turbine, the mixed exhaust gas temperature will in-

Parameters

Exhaust gas bypass, approx.	8 to 12%
Reduction of total exhaust gas amount, approx.	-13%
Total increase of mixed exhaust gas temperature after bypass, up to	+50°C
Increased fuel consumption	1.2% i.e. 2 g/kWh

Table I: Open exhaust gas bypass for power turbine

Parameters

Exhaust gas bypass, approx.	8 to 12%
Reduction of total exhaust gas amount, approx.	-13%
Total increase of mixed exhaust gas temperature after bypass, up to	+65°C
Increased fuel consumption	1.2% i.e. 2 g/kWh

Table II Open exhaust gas bypass for increased boiler performance

crease further by about 15°C, as stated in Table II.

For engines tuned for WHRS, MAN Diesel & Turbo can issue a data report on request, which contemplates the basis for the layout of the whole WHRS, including exhaust boilers, steam and power turbine, condenser, etc. MAN Diesel & Turbo in Copenhagen can also be contacted for engine data.

Exhaust gas boiler and steam systems

The exhaust gas boiler and steam turbine systems analysed in this paper are based on the single and dual steam pressure systems. A higher number of pressure levels is possible, as used within power plant technology, but for marine installations single and dual pressure is the normal standard.

Single-pressure steam system

The simple single-pressure steam system only utilises the exhaust gas heat, see the process diagram in Fig. 20 and the corresponding temperature/heat transmission diagram in Fig. 21. The steam drum from the oil fired boiler can also be used instead of a separate steam drum.

The single steam pressure system is less complex and easy to operate, but the possible efficiency of the total steam circuit (exhaust boiler and steam turbine) will be less than the more used dual pressure steam system.

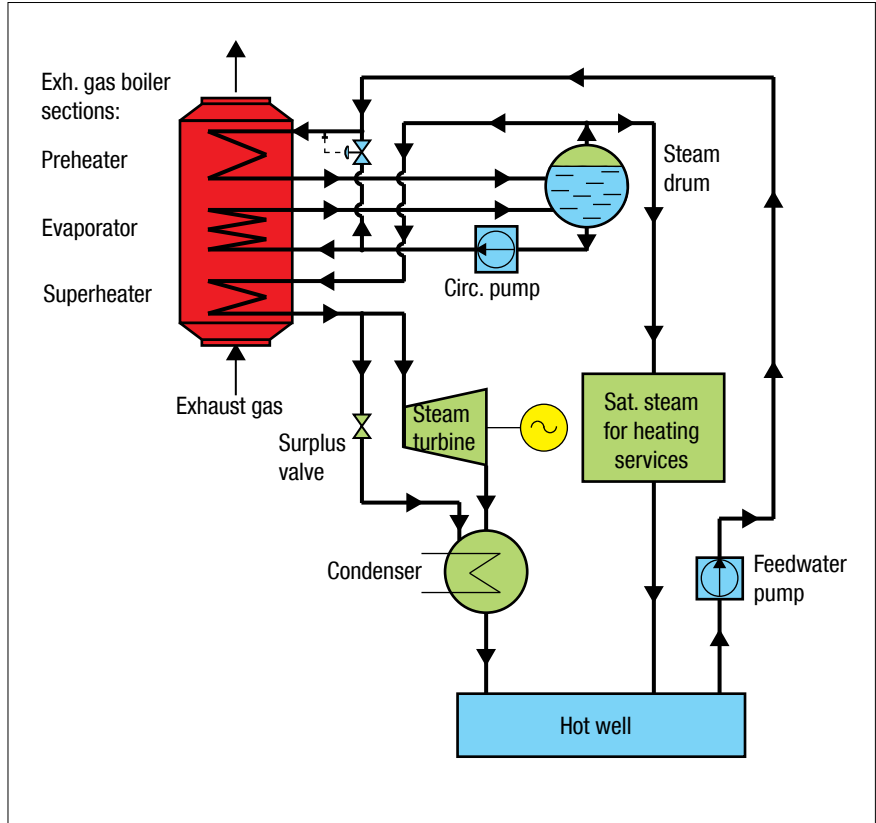

Fig. 20: Process diagram for the single pressure exhaust gas boiler system

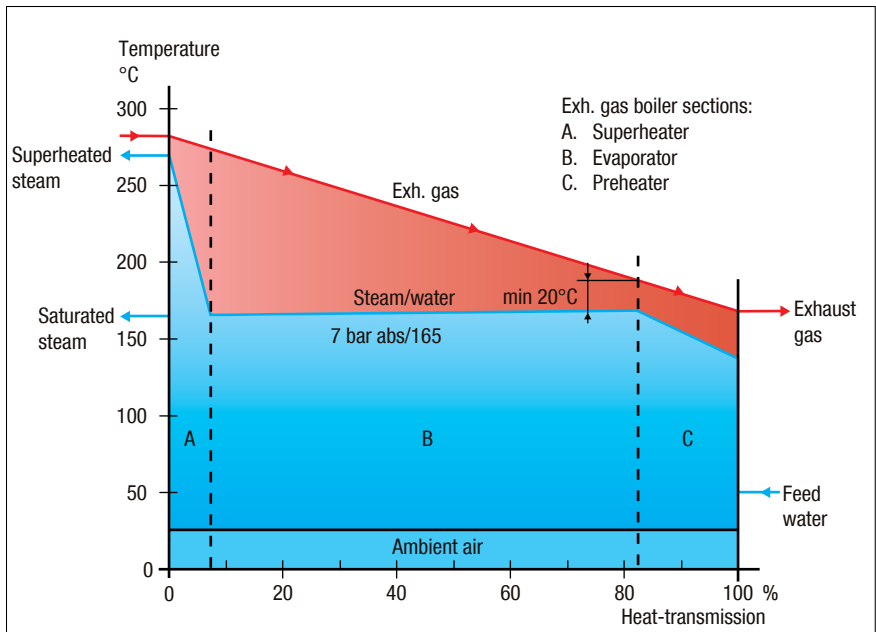

Fig. 21: Temperature/heat transmission diagram for the single pressure steam system

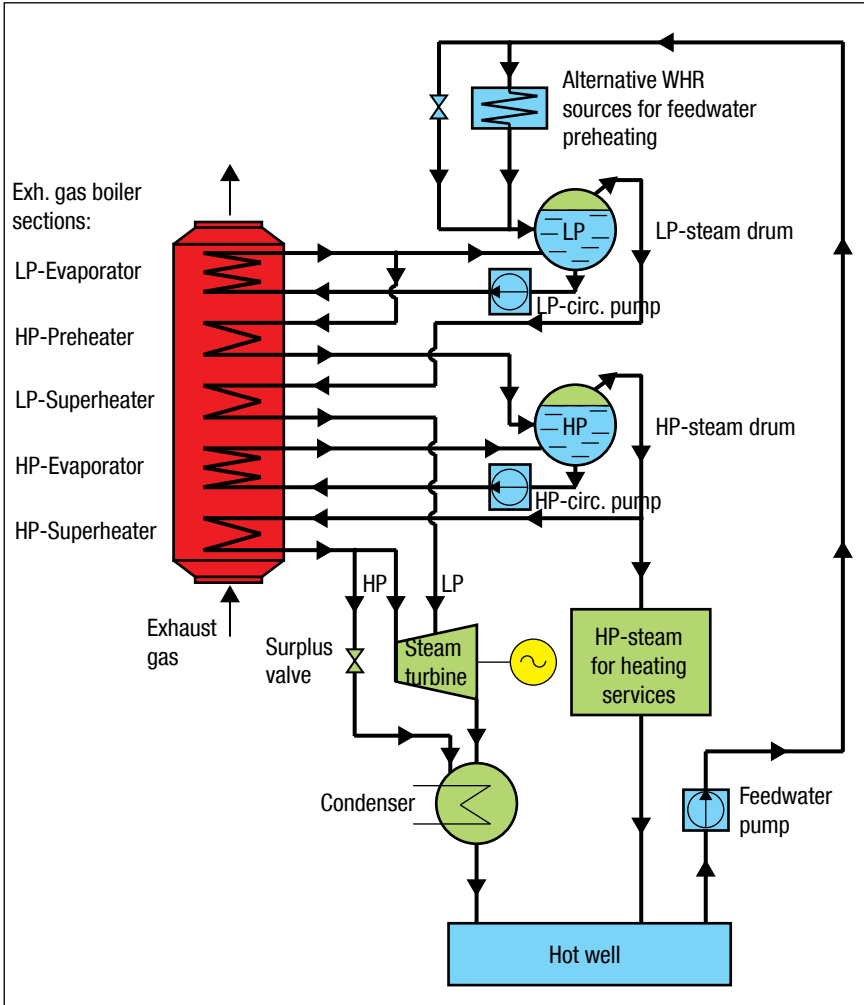

Fig. 22: Process diagram for the dual pressure exhaust gas boiler system

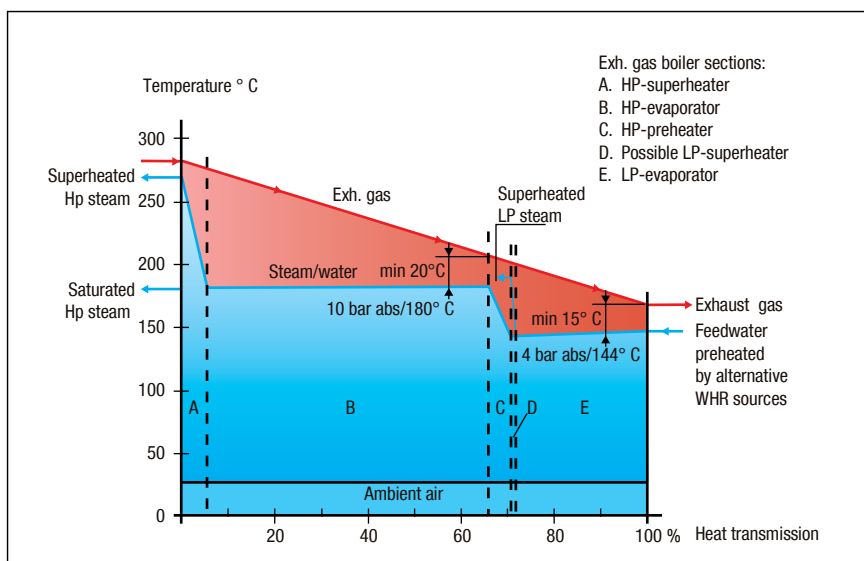

Fig. 23: Temperature/Heat transmission diagram for the dual pressure steam system

Dual-pressure steam system

When using the dual-pressure steam system, it is not possible to install an exhaust gas low-pressure preheater section in the exhaust gas boiler, because the exhaust gas boiler outlet temperature would otherwise be too low and increase the risk of wet (oily) soot deposits on the boiler tubes. Too low an exhaust boiler outlet temperature may result in corrosion in the exhaust piping when running on normal HFO with sulphur content.

The more complex dual-pressure steam system, therefore, needs supplementary waste heat recovery (WHR) sources (jacket water and scavenge air heat) for preheating feed water, which will increase the obtainable steam and electric power production of the WHRS, see the process diagram in Fig. 22 and the corresponding temperature/heat transmission diagram in Fig. 23.

If no alternative waste heat recovery sources are used to preheat the feed water, the low pressure (LP) steam may be used to preheat the feed water, involving an about 16% reduction of the total steam production.

The available superheated steam used for the steam turbine is equal to the surplus steam after deduction of the saturated steam needed for heating services.

The exhaust gas boiler has to be designed in such a way that the risk of soot deposits and fires is minimised, Ref. [3]. For tube type exhaust boilers, which is the boiler type normally used for WHRS, it is further recommended to install a bypass that allows exhaust

gas to be bypassed the exhaust boiler when the engine load is below 30% SMCR, or in case of other malfunctions of the steam system.

Today, the dual steam pressure system is more or less the standard on large container ships applying WHRS.

Steam and water diagram – ME WHRS element

As described in the introduction, WHRS utilises the otherwise wasted energy in the exhaust gas, but we also utilise the energy in the main engine jacket water (high temperature freshwater cooling circuit) and the main engine scavenge

air cooling by applying an main engine WHR element.

Both of these heat exchangers are used to heat up the steam system feed water to a temperature level just below the evaporation temperature for the selected steam pressure.

The steam water diagram, Fig. 24, shows the connections between the different parts in the system – the LP and HP economisers, their circulation pumps, feed water pumps, vacuum condenser, LP and HP drums, hot-well tank, etc.

Control valves in front of the steam turbine cover both start up functions and the possibility of dumping steam if required by the operational condition.

MAN Diesel & Turbo furthermore recommends that a bypass line is arranged for the main engine WHR element to secure a continuous flow through the heat exchanger. If the water in the HP drum reaches a high level, the feed water access to the drum will be closed and the bypass line will be opened and used for securing the flow through the main engine WHR element.

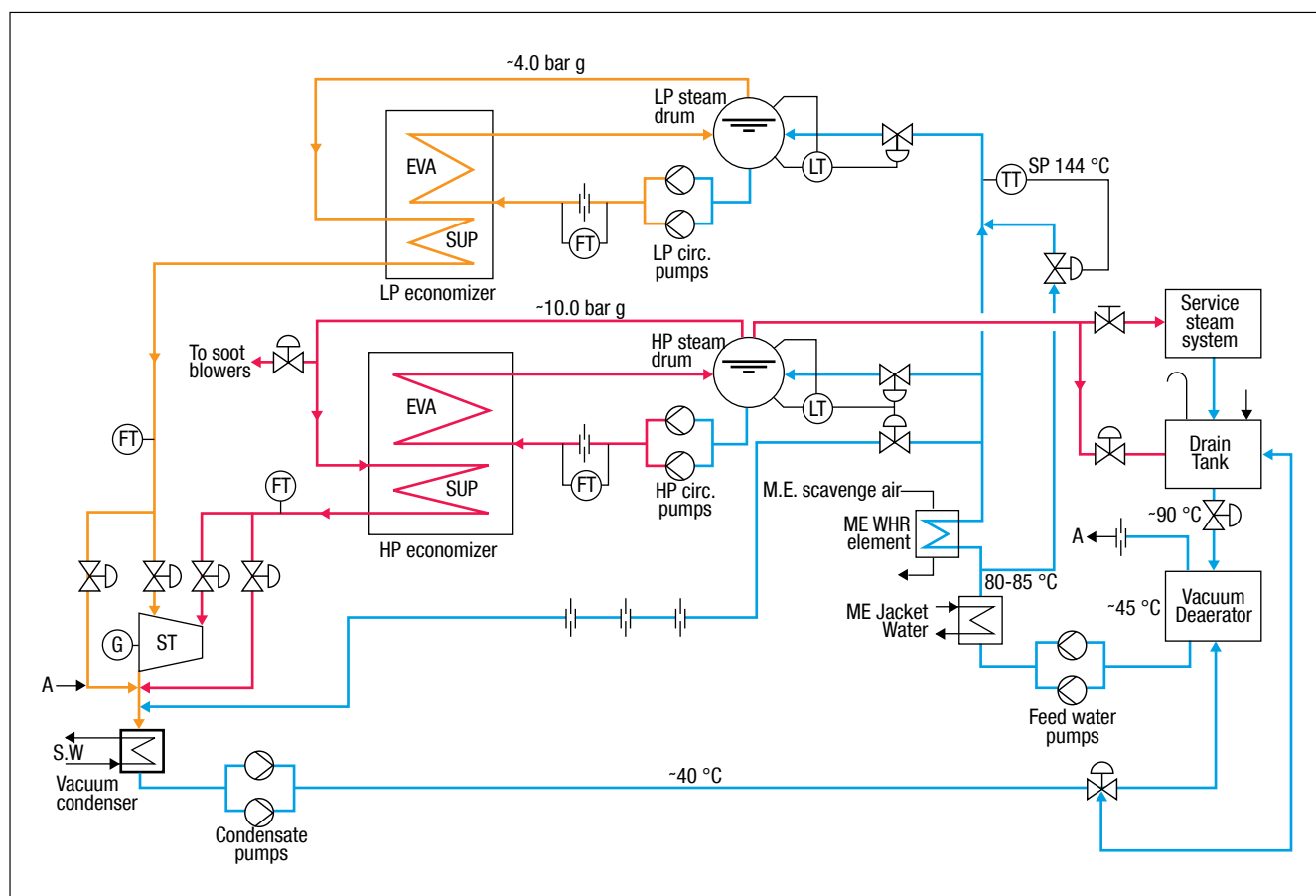

Fig. 24: Recommended steam and water diagram for a dual pressure WHRS

Main engine steam production power (SPP) guarantee

Today, MAN Diesel & Turbo offers engine data for engines tuned for WHRS. It also includes a steam production power (SPP) guarantee, guaranteeing the energy level available for the exhaust boiler.

SPP is defined as follows:

$$SSP[kW]=1.06\left[\frac{kJ}{kg^{\circ}C}\right] \times (MixedExhaustGasTemp[^{\circ}C] - 160[^{\circ}C]) \times ExhGasAmount\left[\frac{kg}{h}\right] \times \frac{h}{3600s}$$

Considering that the required matching parts for the turbocharger and power turbine are unknown before running the specific engine, it is necessary to have sufficient tolerance on the guarantee figure.

The SPP guarantee is provided with a tolerance of +/-7 %-points.

It will be possible/allowed to adjust one at the expense of the other to obtain the best possible steam power production (SPP).

The exhaust temperature and amount are not guaranteed independently.

The above exhaust gas amounts and temperature are valid under the following conditions:

- ISO ambient conditions, ISO 3046/1-1995(E):
- scavenge air coolant temperature 25°C
- ambient air pressure 1000 mbar
- ambient air temperature at turbocharger intake 25°C
- exhaust gas back pressure 30 mbar

For other reference conditions, the following corrections of the exhaust gas temperature and amounts apply at a retained cylinder max. pressure:

	Exhaust Gas Temperature	Exhaust Gas Amount
Scav. air coolant temperature per 10°C rise	+ 1.0°C	+ 2.2%
Blower inlet temperature per 10°C rise	+ 17.0°C	- 5.0%
Blower inlet pressure per 10 mbar rise	- 0.1°C	+ 0.3%
Exhaust gas back pressure per 10 mbar rise	+ 5.0°C	- 1.2%

With a 1°C increase of the seawater temperature, a corresponding 1°C increase of the scavenge air temperature will occur. For the scavenge air temperature, an increase of 12°C over the scavenge air coolant temperature is to be used, so that 37°C scavenge temperature will be the reference value at ISO ambient conditions at SMCR, and lower scavenge air temperature at part load.

Obtainable Electric Power of the WHRS

Very often, owners or shipyards ask us: “what can we expect of the recovery ratio when installing a WHRS on our new ship project”. Fig. 25 gives a rough indication of the potential of installing WHRS – depending on the selected type of WHRS.

When more exact WHRS values are needed, MDT will need some more information for the particular ship project in order to guide and provide data for the WHRS most suitable for the project.

The information needed is the ship type, size, speed range, preferred main engine type, engine rating, operational profile, electric power needed at sea, any number of reefer containers, need for power take in (PTI) and/or power take off (PTO), intentions concerning the use of the recovered WHRS energy, the use of PTO and PTI at the different running modes, service steam amount at sea (tropical, ISO and Winter conditions), etc.

Waste Heat Recovery Systems	
	Max. electrical recovery %
TCS – PTG:	3 to 5
STG – Single pressure system:	4 to 7
STG – Dual pressure system:	5 to 8
Full WHRS (ST - PT):	8 to 11
All depending of engine type, size and rating	

Fig. 25: WHRS recovery ratios

Power and steam turbine generator output – dual pressure

When ship project information, as mentioned in the previous section, is available, MDT will be able to put together the best WHRS that meets the needs of the ship.

Fig. 26 presents a typical data set for a large container ship project with a full WHRS with both steam and power turbines.

To ensure reliable WHRS output data for a project at ISO condition, the ship’s HP service steam data must also be given at ISO condition. A higher WHRS output can be ensured if part of the ship’s service steam for heating is delivered by the low pressure (LP) steam system leaving the high pressure steam for the steam turbine.

		Load Point	100% SMCR	90% SCMR	85% SCMR	70% SCMR	60% SCMR	50% SCMR
WHS data based on:								
MAN B&W 10S90ME-C9.2		HP Steam at Turbine Inlet						
	Pressure	bar(a)	10.0	9.2	8.6	7.4	6.7	6.5
	Temperature	°C	259	258	257	254	254	256
Power:	Flow	t/h	11.83	10.88	10.31	8.99	8.10	6.97
48,510 kW								
Bypass:		HP Service Steam						
11.6%	Flow	t/h	1.00	1.00	1.00	1.00	1.00	1.00
	Pressure	bar(a)	10.7	9.7	9.2	7.7	6.9	6.8
Recovery rate:		LP Steam at Turbine inlet						
8.6% at 90% SMCR	Pressure	bar(a)	4.5	4.5	4.5	4.5	4.5	4.5
	Temperature	°C	148	148	148	148	148	148
	Flow	t/h	3.92	3.39	3.09	2.28	1.787	1.45
Service steam:		Condensing Steam						
1.0 ton/h	Pressure	bar(a)	0.057	0.052	0.049	0.045	0.045	0.045
	Temperature	°C	35.3	33.6	32.5	31.0	31.0	31.0
	Flow	t/h	15.75	14.27	13.40	11.27	9.88	8.42
At ISO conditions		Output						
	Steam turbine	kW	2,477	2,248	2,108	1,766	1,539	1,280
	Power turbine	kW	1,836	1,515	1,360	1,766	754	526
	Total Generator Output	kW	4,313	3,763	3,468	2,747	2,293	1,806

Fig. 26: WHRS recovery output data for a large container ship.

Main engine load – % SMCR

MAN 10S90ME-C9.2

Power: 48,510 kW

Bypass: 11.6%

Recovery rate: 8.6%
at 90% SMCR

Service steam: 1.0 ton/h

At ISO condition, Tropical
and Winter

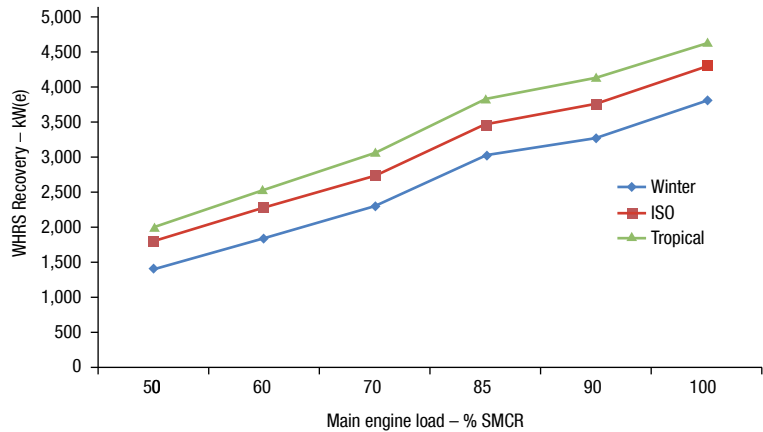

Fig. 27: WHRS recovery output data for a large container ship

Graphs for the recovery can be seen at Fig. 27, both for tropical, ISO and winter conditions.

Payback time for waste heat recovery system

When looking at a new ship project, and evaluating whether including WHRS in the project is a good idea, the question about payback time will always come up.

In order to evaluate payback time for a project, one of the key elements is to have information about the expected operational profile for the new ship.

The operational profile of the ship varies most in relation to ship types, see fig. 28, where bulk carriers and tankers, typically, are running at a given ship speed whenever they are at sea, whereas big container ships with a higher daily fuel consumption have a more diversified running pattern. In the time after 2008 more and more slow and super slow steaming of ships have

Sailing time – %

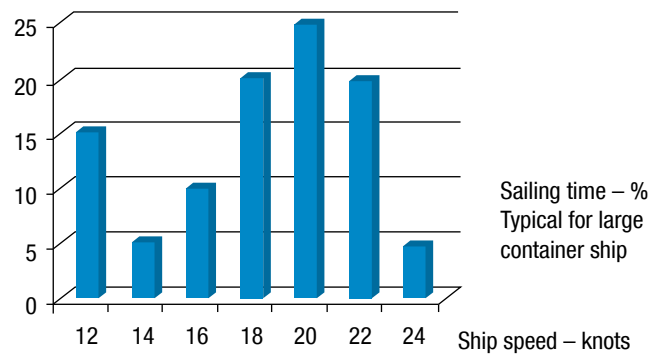

Sailing time – %

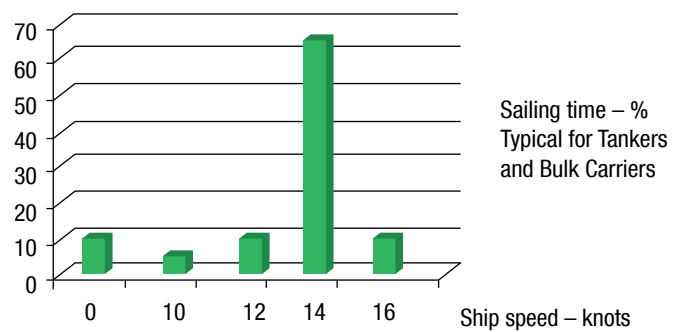

Fig. 28: Typical operational profiles

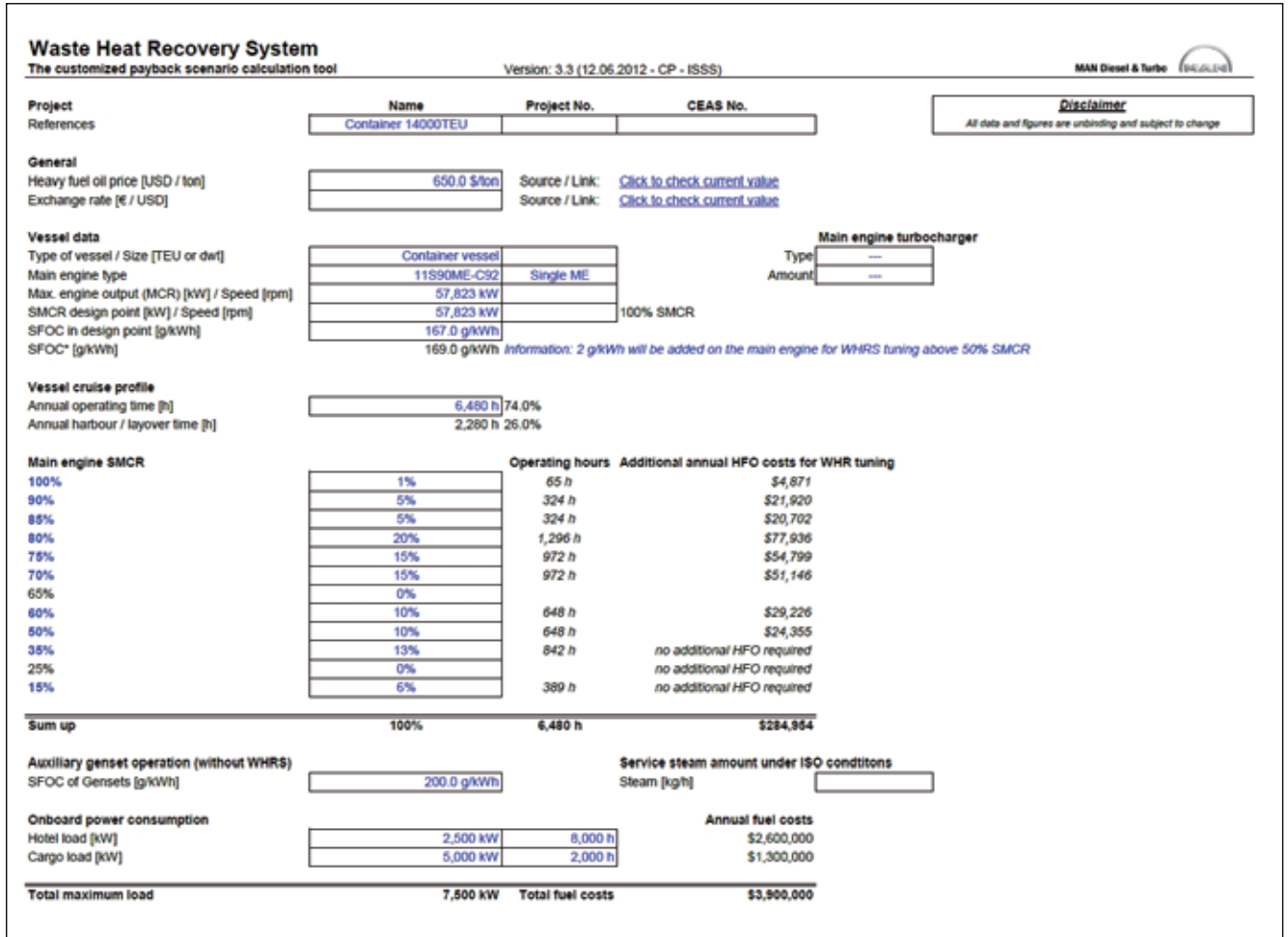

Fig. 29: Container ship operation profile

affected the operational profile and even top speed of ship design.

When taking the operational profile of the ship into the equation of whether WHRS will provide an acceptable payback time, the above running patterns must be transformed into engine loads and running hours for the engine load – an example for a container ship project is shown in the following figures.

Fig. 29 shows the given operational profile transformed into engine loads and operational hours at these loads, also the annual added fuel costs for tuning the engine for WHRS are shown

– the effect of allowing the engine to use 2 g/kWh more to increase the exhaust temperature and support bypass for power turbine down to 40% main engine load.

The above given operational profile for a container ship is typical for the situation today where operation is affected strongly by high fuel prices and low container rates.

Based on the operational profile and the WHRS output, the pay-back time for the project can then be calculated, see Fig. 30. Fig. 31 shows the operational profile and the WHRS output in a graphic form.

The above payback calculation includes shipyard installation and commissioning costs, which vary from shipyard to shipyard – estimated here – to be able to show realistic payback times for both full WHRS STPT, WHRS STG and WHRS PTG solutions.

The payback time can also be calculated based on a net present value calculation, which can be seen in Fig. 33 and which shows a payback time of around 4.3 years. But what is probably more interesting for an owner, which keeps his ships for 20 years, is a fuel cost saving of USD 36 million for a full WHRS for the ship lifetime.

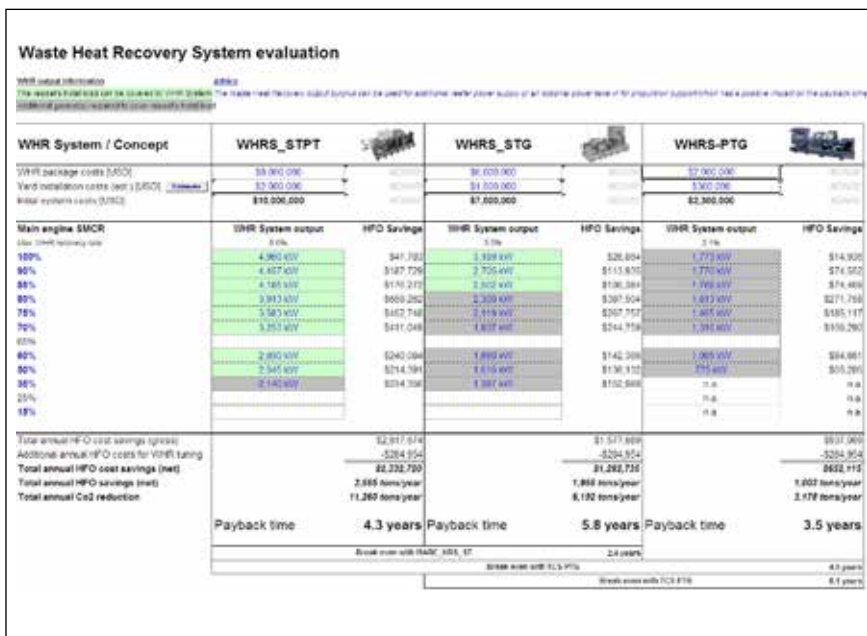

Fig. 30: Large container ship WHRS output and payback calculation for WHRS

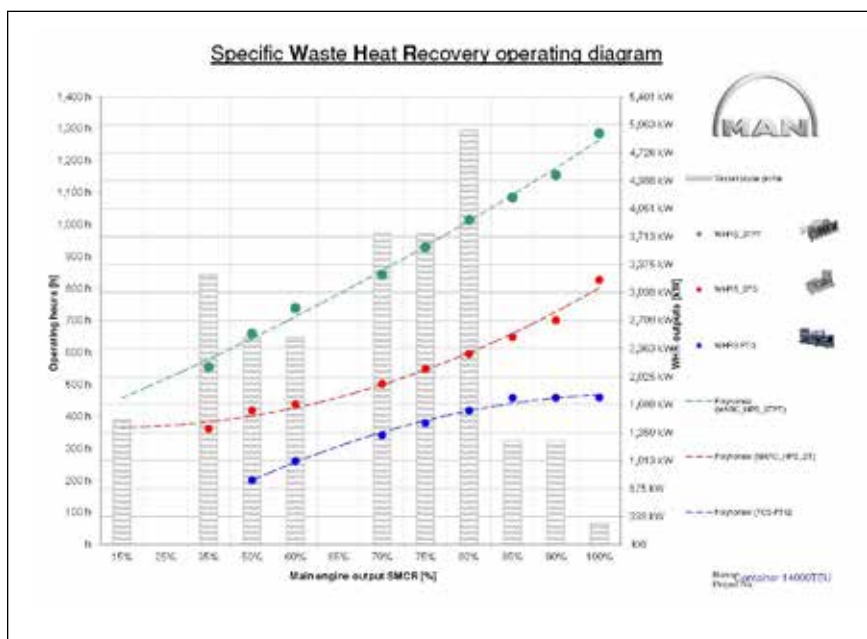

Fig. 31: Large container ship project operational profile and WHRS outputs

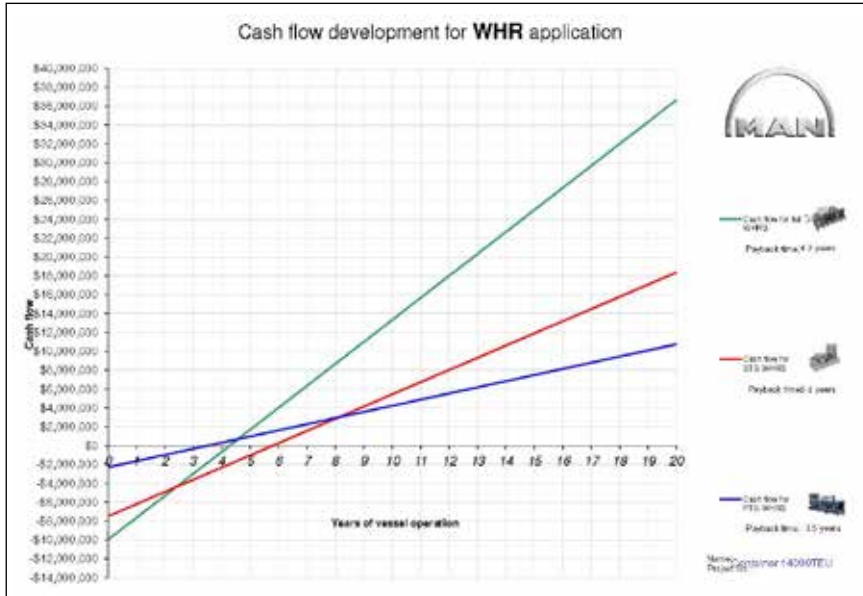

Fig. 32: Large container ship payback calculation for WHRS – net present value

Emission Effects of using WHRS

Based on a HFO fuel saving of 3,555 tons per year (with 3% sulphur content), the installation of a WHRS on a large container ship, as illustrated in Fig. 30, will save the environment for the following emission amounts:

CO₂ emission saving per year: 11,260 tons
 NO_x emission saving per year: 319 tons
 SO_x emission saving per year: 214 tons
 Particulates saving per year: 29 tons

WHRS Effect on Ship's EEDI

WHRS is not only good for the fuel economy of the ship, but also for the IMO required energy efficiency design index (EEDI), which is required for all new ships with keel laying after 1 January 2013.

The shipowner organisation BIMCO has made an effective tool for the calculation of EEDI, see Ref. [4].

When using data from the payback calculation and the necessary ship data, i.e. ship capacity (dwt), ship index speed (knots), etc., the expected EEDI figure can be calculated, as shown in the following four figures – the first two are the containers ship without WHRS and the last two with WHRS.

When using the BIMCO tool, it is important to note that the SFOC (g/kWh) figure applied is the main engine SFOC figure at index condition (= 75% SMCR), including a +6% tolerance, as the EEDI of the ship must be shown at sea trial for compliance with IMO regulations.

Fig. 33 and 34 show the attained EEDI for a container ship **without** WHRS included in the calculation – an attained EEDI value of 13.114 g CO₂/dwt T x mile.

When taking the WHRS output at index condition, as shown in Fig. 36, to be 3,600 kW of innovative energy efficiency technology – the attained EEDI can be calculated as shown in Fig. 37.

The WHRS added to this 11000 TEU container ships reduction in EEDI – from 13.114 down to 12.009 gram CO₂/dwt x mile i.e. a reduction of 9.2%.

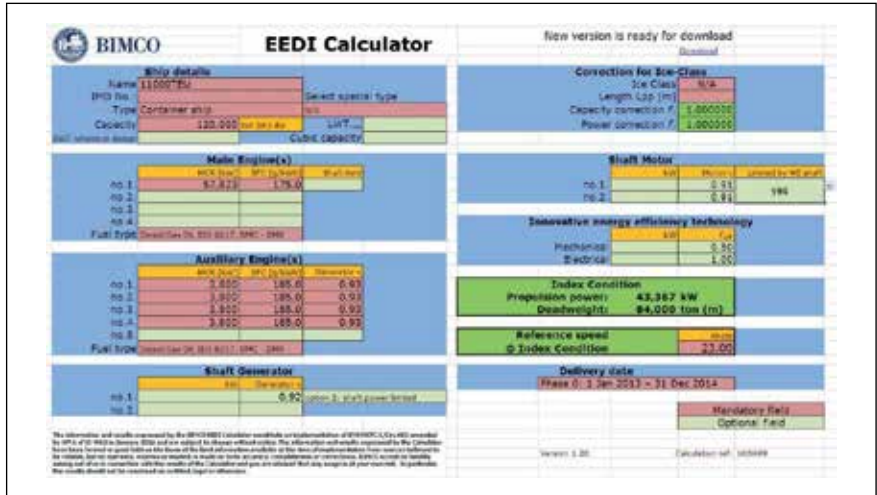

Fig. 33: 11,000 teu container ship without WHRS

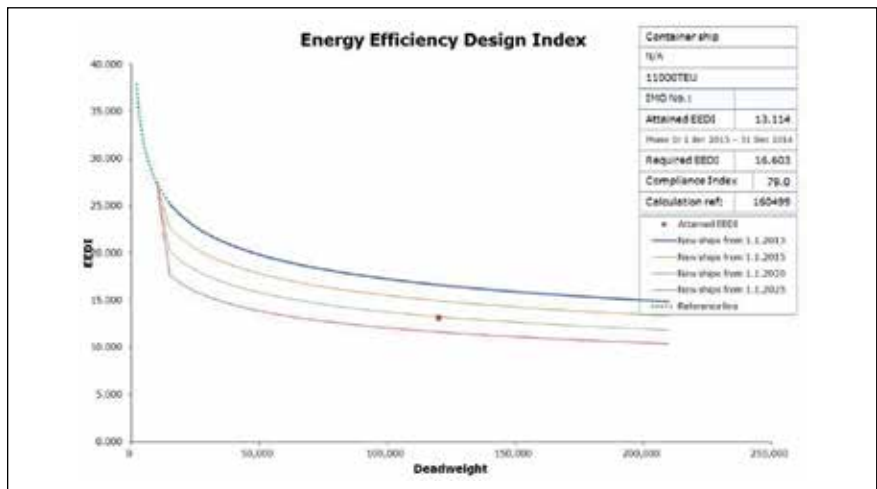

Fig. 34: 11,000 teu container ship without WHRS – attained EEDI

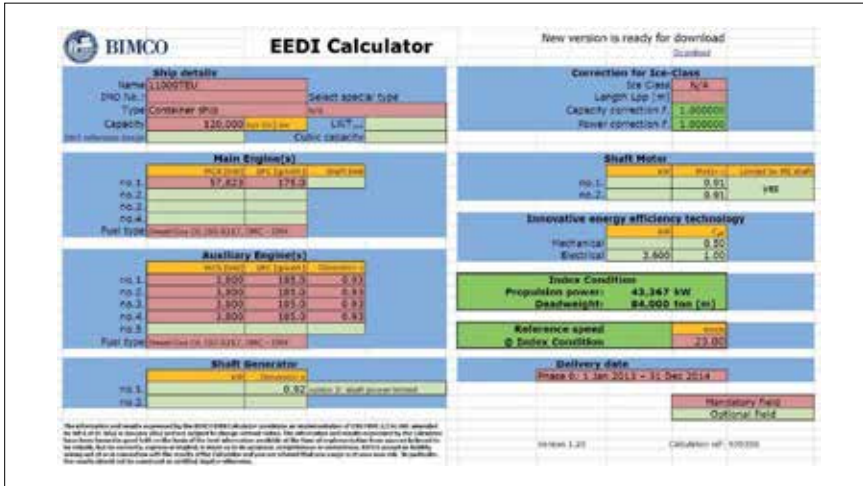

Fig. 35: 11,000 TEU Container ship WHRS.

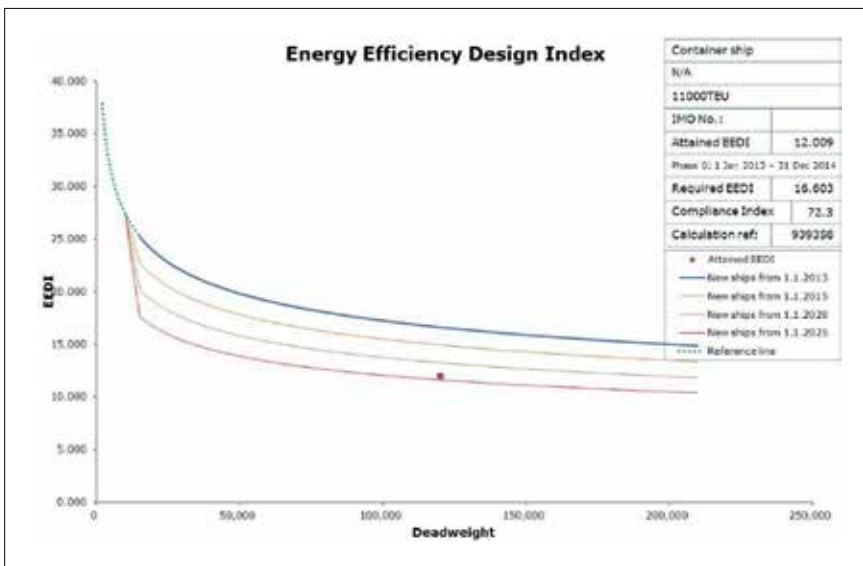

Fig. 36: 11,000 teu container ship with WHRS – attained EEDI

Conclusion

This paper shows that significant fuel cost savings can be achieved by adding a WHRS to a ship project. Whether a full WHRS (ST & PT), a stand-alone WHRS (STG) or WHRS (PTG) solution are selected, all of these solutions offer large fuel savings.

Fuel reductions of between 4-11% are possible, depending on the selected WHRS solution, main engine power level, electric need at sea, operational profile, etc. The larger the engine power, the greater the possible fuel saving.

In addition to large fuel savings, a WHRS gives large CO₂, NO_x, SO_x and particulate reductions to the benefit of the environment.

The payback time is short for all three WHRS solutions, which alone can give the shipowner high fuel savings throughout the lifetime of the ship.

Furthermore, a WHRS will rather substantially reduce the ship's energy efficiency design index – same reduction level as the WHRS recovery ratio – thereby helping the shipowner meet even tighter EEDI requirements from IMO in the future.

Reference

- [1] Basic Principles of Ship Propulsion, MAN Diesel & Turbo SE, Copenhagen, Denmark, December 2011.
- [2] TCS-PTG Savings with Extra Power, MAN Diesel & Turbo SE, Augsburg, Germany, December 2011.
- [3] Soot Deposits and Fires in Exhaust Gas Boilers, MAN Diesel & Turbo SE, Copenhagen, Denmark, March 2004.
- [4] BIMCO EEDI Calculator, link: <https://www.bimco.org/Products/EEDI.aspx>

Nomenclature / abbreviations

CAMS	Control, Alarm and Monitoring System
CFD	Computational Fluid Dynamics – a tool which can simulate exhaust gas flow into the exhaust boiler
EEDI	Energy Efficiency Design Index
EGB	Exhaust Gas Bypass – used in connection with engine tuning
EVA	Evaporator - steam
HP	High Pressure - steam
LP	Low Pressure - steam
MDT	MAN Diesel & Turbo
ME-ECS	Engine Control System for MDT ME engines – electronically engine
MaxBP	Maximum By-pass
MinBP	Minimum By-pass
ORC	Organic Rankine Cycle – energy recovery system based on synthetic fluid for energy transportation
PMS	Power Management System – system to control energy producers (Aux. diesel gensets, WHRS unit, PTO) and energy consumers
PTG	Power Turbine Generator unit
PTI	Power Take In – electric motor or Power Turbine, where the produced mechanical power is used for propulsion boost or boost of a PTO solution (Renk)
PTO	Power Take Off – generator driven by main engine via gears (Renk solution) or generators mounted directly on propulsion drive line.
RCS	Remote Control System for main engine
SG/SM	Shaft Generator/Shaft Motor
SFOC	Specific Fuel Oil Consumption
SMCR	Specified Maximum Continuous Rating
SPP	Steam Production Power – a value for the available exhaust energy for steam production
STG	Steam Turbine Generator unit
ST-PT	Steam and Power Turbine generator unit
SUP	Super Heater – steam
TCS-PTG	MDT product name for PTG: – Turbo Compound System – Power Turbine Generator unit.
WHR	Waste Heat Recovery
WHRS	Waste Heat Recovery System
WHRS STPT	Full WHRS with both Steam Turbine (ST) and Power Turbine (PT) arranged as a unit with gear and generator
WHRS STG	WHRS with Steam Turbine (ST), gear and generator (G) arranged as a unit
WHRS PTG	WHRS with Power Turbine (PT), gear and generator (G) arranged as a unit

All data provided in this document is non-binding. This data serves informational purposes only and is especially not guaranteed in any way. Depending on the subsequent specific individual projects, the relevant data may be subject to changes and will be assessed and determined individually for each project. This will depend on the particular characteristics of each individual project, especially specific site and operational conditions. Copyright © MAN Diesel & Turbo. 5510-0136-03ppr Aug 2014 Printed in Denmark

MAN Diesel & Turbo

Teglholmegade 41
2450 Copenhagen SV, Denmark
Phone +45 33 85 11 00
Fax +45 33 85 10 30
info-cph@mandieselturbo.com
www.mandieselturbo.com